

Datenblatt:

931+0089+000

LM 0-0-1 WH (8 Kg)

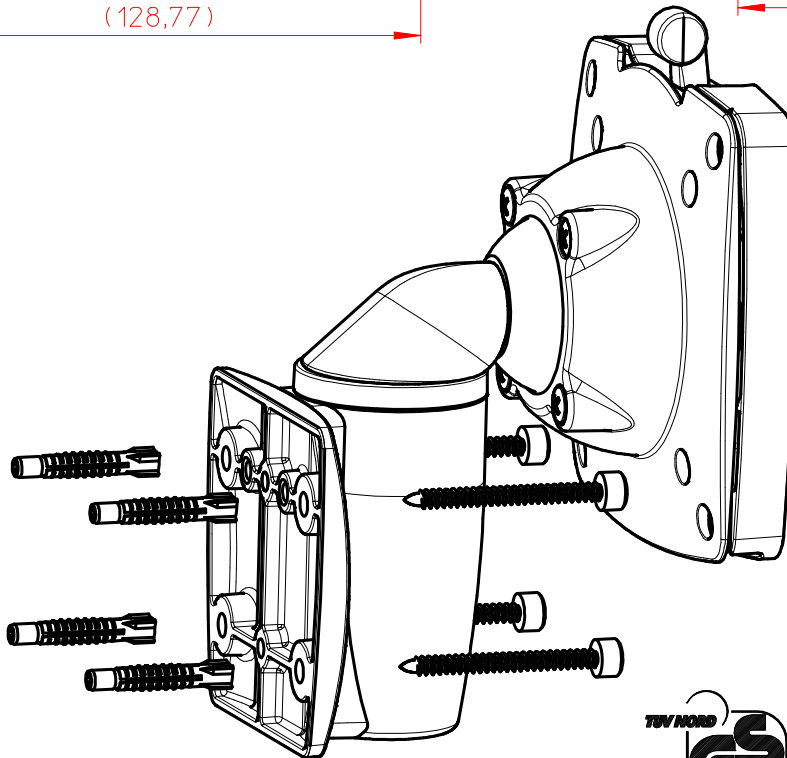
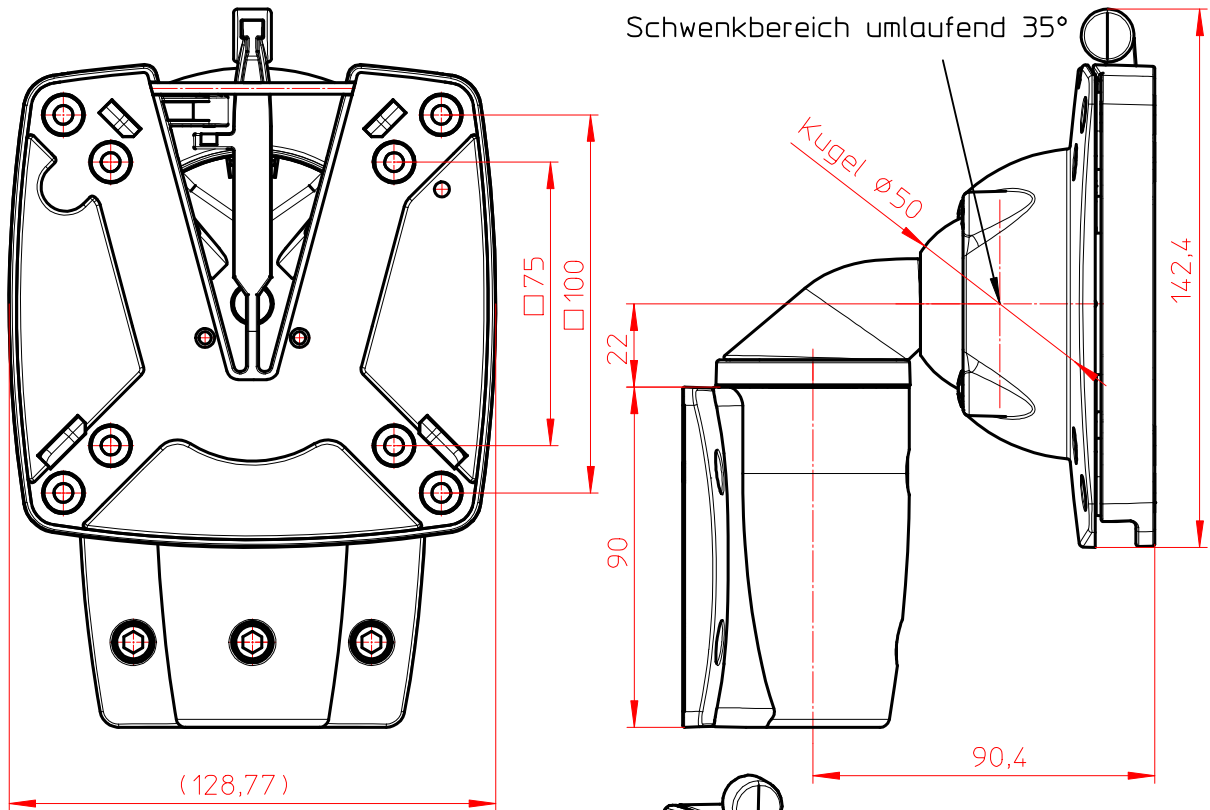

Technische und Design Änderungen vorbehalten!  
Technical and design modifications reserved! 14.10.10